



OUR WEBSITE

MOORE CONCRETE

QUALITY PRECAST SOLUTIONS



CE MARKED

QUIKBLOC

An interlocking style block for both temporary and permanent structures



QUIKBLOC

Product Features

QuikBloc is an interlocking style block and is ideal for both temporary and permanent structures. The interlocking blocks create a strong structure with no need for bonding or fixing, as well as providing flexibility which allows structures to be modified or extended with ease. Installation and relocation of the blocks is fast and simple as the blocks are manoeuvred using the R Anchor(s) wh cast into the top of each block.

Product Dimensions

CE Manufactured to EN 15258

Product Type	Length (mm)	Width (mm)	Height (mm)	Weight (kg)
Full Block (Standard)	1400	700	700	1600
Half Block (Standard)	700	700	700	800
Full Block (Large)	1600	800	800	2400
Half Block (Large)	800	800	800	1200
Half Block (Height)	1600	800	400	1229

Product Applications

QuikBloc has a variety of uses, including:

- Storage Bays
- Security Perimeters
- Scaffolding
- Earth Retention
- Partition Walls
- Material Segregation
- Coastal Defence

Suitable for the storage of bulk materials including:

- Aggregate
- Grain
- Road Salt/Grit
- Root Vegetables
- Recyclables/Waste
- Fertiliser
- Woodchip/Pellets
- Solid Fuel (Coal)

Please refer to the **Transport, Storage and Construction Information** on our website for guidance on installation and suitability

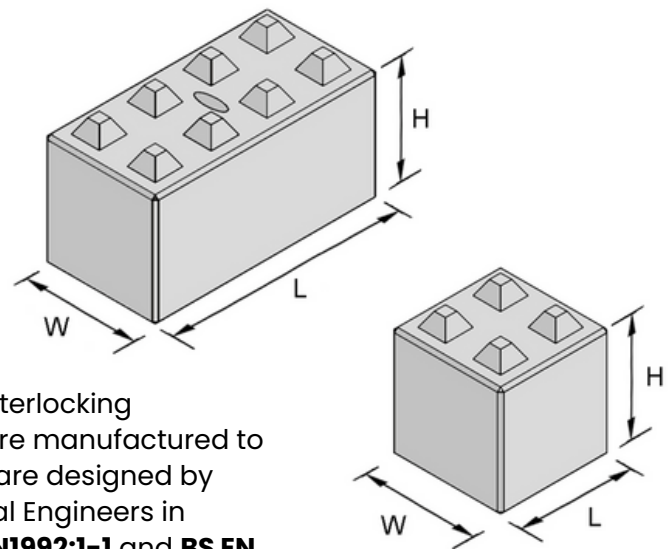

Precast concrete interlocking blocks (QuikBloc) are manufactured to **EN 15258**. QuikBloc are designed by Chartered Structural Engineers in accordance with **EN1992:1-1** and **BS EN 15258:2008**.



Moore Concrete Products Ltd, Caherty House, 41 Woodside Road, Ballymena, County Antrim, Northern Ireland BT42 4QH

Tel: +44 (0) 28 2565 2566

Website: www.moore-concrete.com **Email:** sales@moore-concrete.com

INVESTORS IN PEOPLE
We invest in people Platinum

