

Transport, Storage and Construction Information – Safety Slats

Moore Concrete floor units are designed or load tested by Chartered Structural Engineers in accordance with BS8110; Part 1 and BS5502 Part 22 and 51. Care must be taken during transport, offloading and installation to guarantee the integrity of the units.

The full design strength of the units will only be achieved after **28 days**, the date of manufacture will be labelled on the unit. If this label is missing please contact Moore Concrete for advice. Unit weights are provided on the technical drawing supplied with the order acknowledgement.

The install should be completed by competent persons in line with a specific risk assessment and “Lifting Operations Lifting Equipment Regulations (NI) 1999”. If a crane is required the installation to be completed in line with the Lift Plan conducted in accordance with “*Safe Use of Cranes BS 7121-1:2016*”.

Transport, Handling and Offloading

During transport and temporary storage you must ensure that:

- The units are stacked no more than 6 No. high.
- When loaded on to a vehicle the stacks must be spaced an adequate distance apart to ensure no damage occurs to the units.
- Timber spacers must be positioned at 1/5 points of the overall length, as per the illustration overleaf and the load must be secured with appropriate ratchet straps. The load must be checked for stability before departure.
- Offloading and storage must be done safely and carefully on to firm and level ground
- Timber spacers must be provided between each unit at the recommended positions
- The spacers must be aligned vertically to avoid unnecessary stressing or damage
- The customer should lift and handle the units by either using a forklift or telehandler to lift directly from underneath or by under slinging with appropriate lifting tackle and equipment.
- Lifting Loops will correspond to the load being lifted. Lifting loops can be subjected to a diagonal lift up to 45° (Shown in the diagram below). If a minimum chain angle of 45° cannot be achieved a spreader beam is to be used.

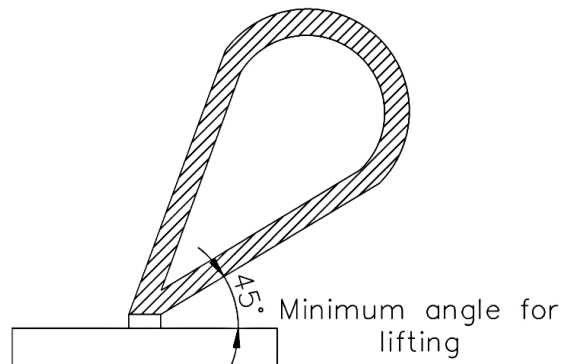

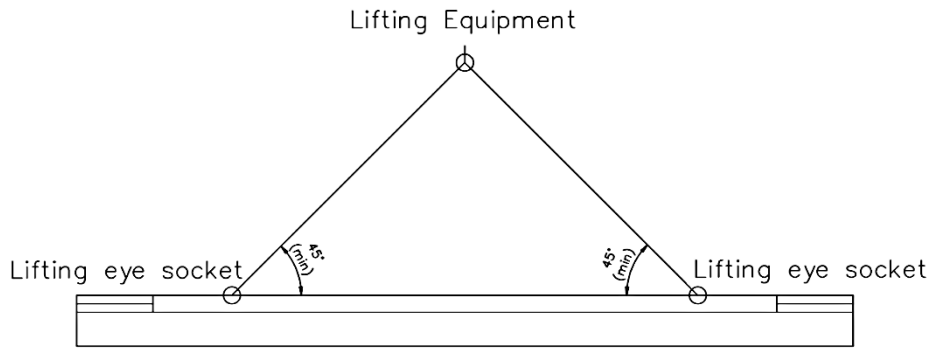

Slings must be sufficiently spread to balance the unit

Timber spacers placed 1/5 of overall length from product ends.

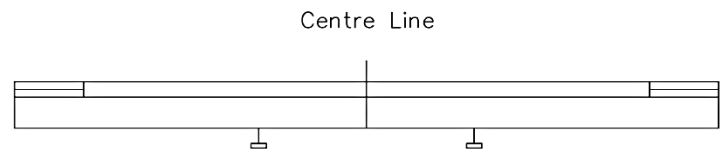
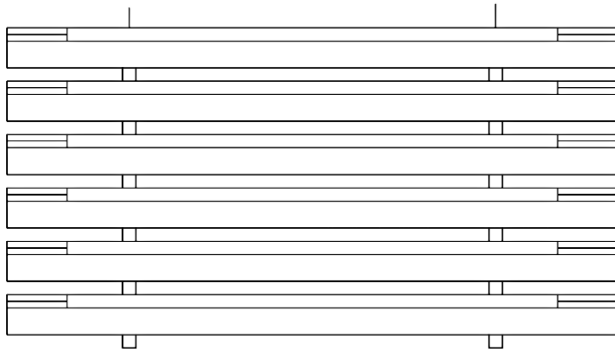

Fork positions must be centred on the panel with as wide a spread as possible when using forklifts/telehandlers.

Installation

During laying of the units the customer must ensure that:

- The units are laid on a smooth and level surface, i.e. the slats or walls should be free of dirt/debris and should be checked for level and alignment along the bearing points. Small tolerances are allowed in the units so carefully check alignment as installation progresses.
- The **minimum end bearing of the units is 100mm on concrete and 150mm on blockwork**, details are shown below.
- Moore Concrete install covers to any manhole openings in the units before despatch. During installation/construction the customer must ensure that these covers are not opened or removed creating a hazard for personnel walking on the top surface.
- If construction works are continuing after the floor installation, steps must be taken to ensure the product is not damaged by any activity or overloaded at any stage. Axle loads can be found with the technical drawing supplied with the order acknowledgement. If in doubt call Moore Concrete for advice.

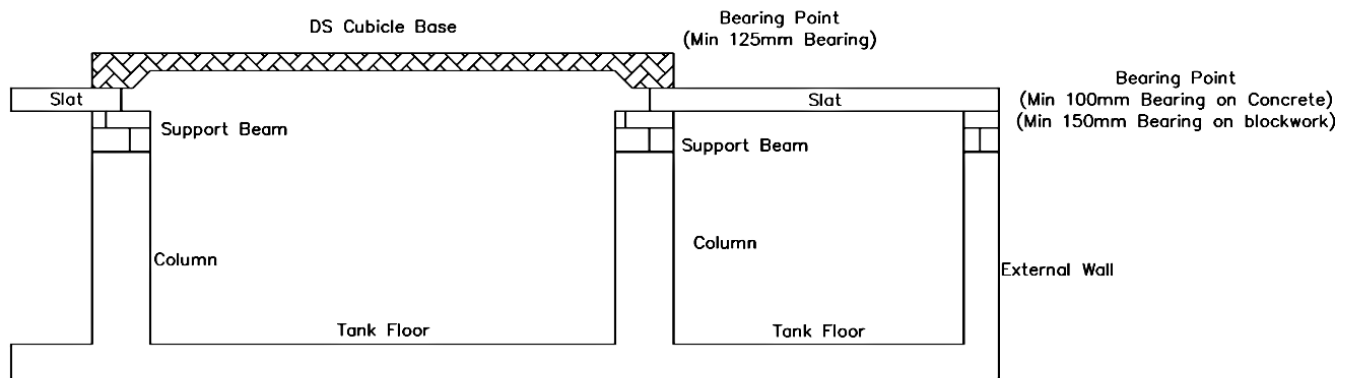

The section through a typical tank above shows the standard bearing detail, the units must bear at least 100mm on concrete and 150mm on blockwork. Care should be taken to ensure that loading capacities are never exceeded, either during construction or during lifespan.

Applicable Units:

Safety Gang 10" Deep/Safety Gang Slat NS/Safety Gang Slat HD/Safety Slat Dust/Dual Purpose Safety/Solid Safety Gang

The manufacturer assumes no liability for damage incurred by Improper handling.

Revised – Sept 2017