

Road Gullies

Trapped gullies (round) eliminate odours through the use of a water seal while untrapped gullies and silt boxes (square) are used for collection of surface water.

Silt Boxes come with one hole tapped out, the remaining three can be tapped out if required.



Silt Box

Untrapped Gully

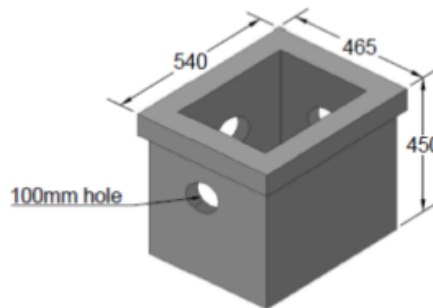
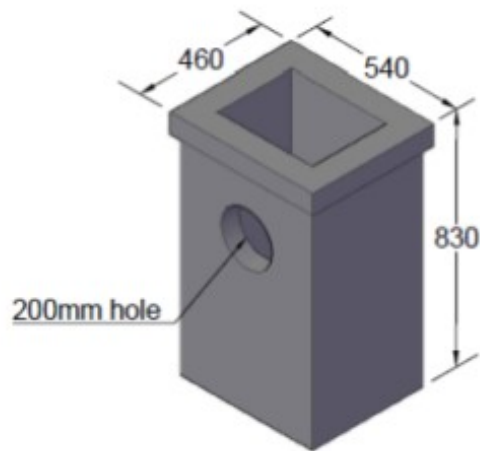

C250 Grates are sold separately and suitable for use with all gullies

“Moore Concrete are always very helpful, only very recently they went the extra mile for a large customer which is brilliant”

Julie Cox at Mole Valley Farmers Ltd, Devon

